

CUM 740

Measuring Transmitter for Turbidity and Solids Content



The CUM 740 transmitter is used for optical solid matter content measurement in clear and turbid water and in sludge.

Since the transmitter can connect a large range of sensors, it covers a wide range of solid matter concentration also at high temperature and in hazardous areas.

Applications

- Closed sewage treatment plant areas, such as inflow, preclarifier, sludge removal
- Process monitoring in high-temperature and hazardous areas in the chemical industry, waste incinerators and steam generation plants

Advantages at a glance

- Transmitter with microprocessor control
- Large selection of sensors for four-beam pulsed light systems
- Large two line display for set-up and measured value display
- Large concentration range from 2 FNU to 150g/l
- Measuring units: g/l, mg/l, TEF, ppm, %
- Menu-controlled set-up and calibration in plain text
- Measured value processing in sensor, giving low signal transmission sensitivity
- Measured value storage using data logger
- Four relay outputs (sensor cleaning, error message, two freely-configurable limit contacts)
- One or two channel versions
- Housing with ingress protection IP 65



Measuring equipment

The complete measuring system for the high temperature range consists of:

- Turbidity transmitter CUM 740
- Turbidity sensor, e.g. CUS 61H, with the components:
 - Sensor head
 - Optical fibre
 - Sensor electronics.

The complete measuring system for hazardous areas consists of:

- Turbidity transmitter CUM 740
- Turbidity sensor, e.g. CUS 63 / CUS 63H with the components:
 - Sensor head
 - Optical fibre (for high temperatures)
 - Intrinsically safe sensor electronics
- Zener barrier.

Measuring system
CUM 740
with CUS 61H-A2

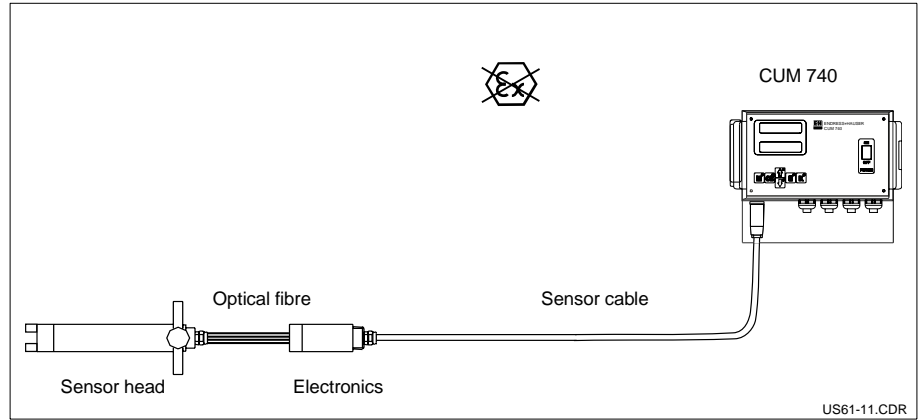

Measuring system
CUM 740
with CUS 62-G1

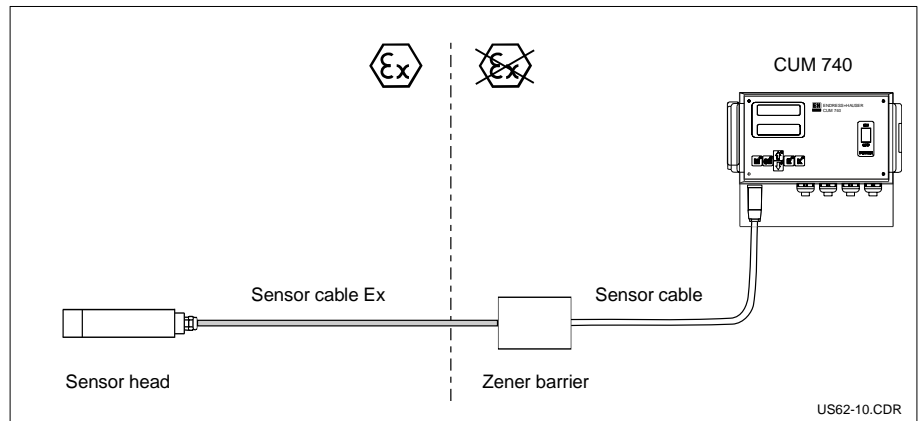

Measuring system
CUM 740
with CUS 63H-G2

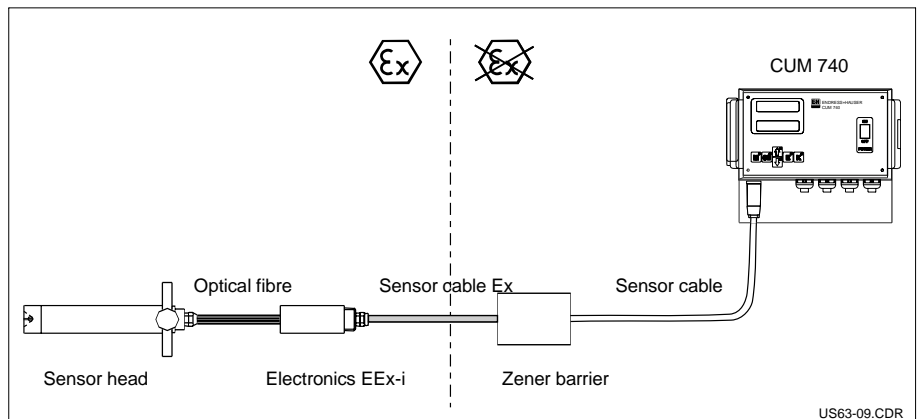

Measuring system
CUM 740
with CUS 61H-G3

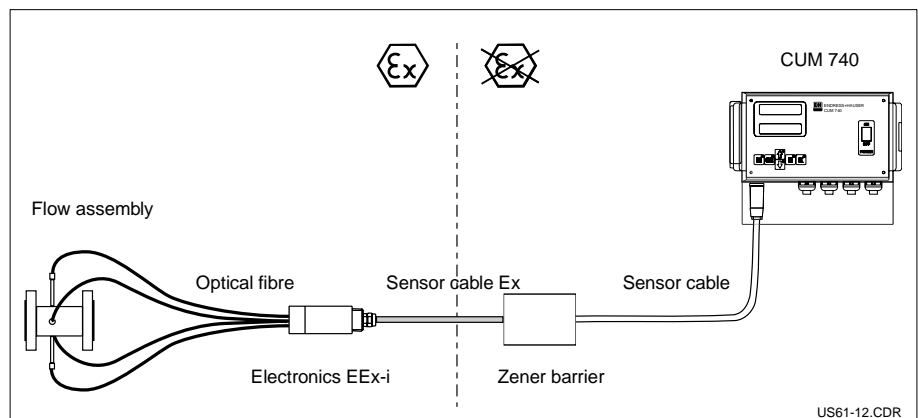

Measuring principle

Signal processing

Measured value preprocessing takes place in the sensor. The connectable sensors operate using the four-beam pulsed light method.

Turbidity is determined using different optical measuring methods depending on the sensor connected:

- Absorption light method
- Backscatter light method
- 90° scattered light method.

The sensor generates a turbidity or solids-dependent signal which is converted into a frequency signal. The frequency signals are assigned to corresponding turbidity units and solid matter contents, and are shown in the transmitter display.

Operation

The CUM 740 is fully set up and calibrated in a menu-assisted software using a dirt-proof membrane keypad. The operator is guided interactively through the operating menu. The interface is a two-line plaintext display.

Programming levels which go beyond everyday operation processes are only accessible by entering a password.

All the calibration data and parameters are retained if there is a power failure or when the device is shut down (non-volatile RAM).

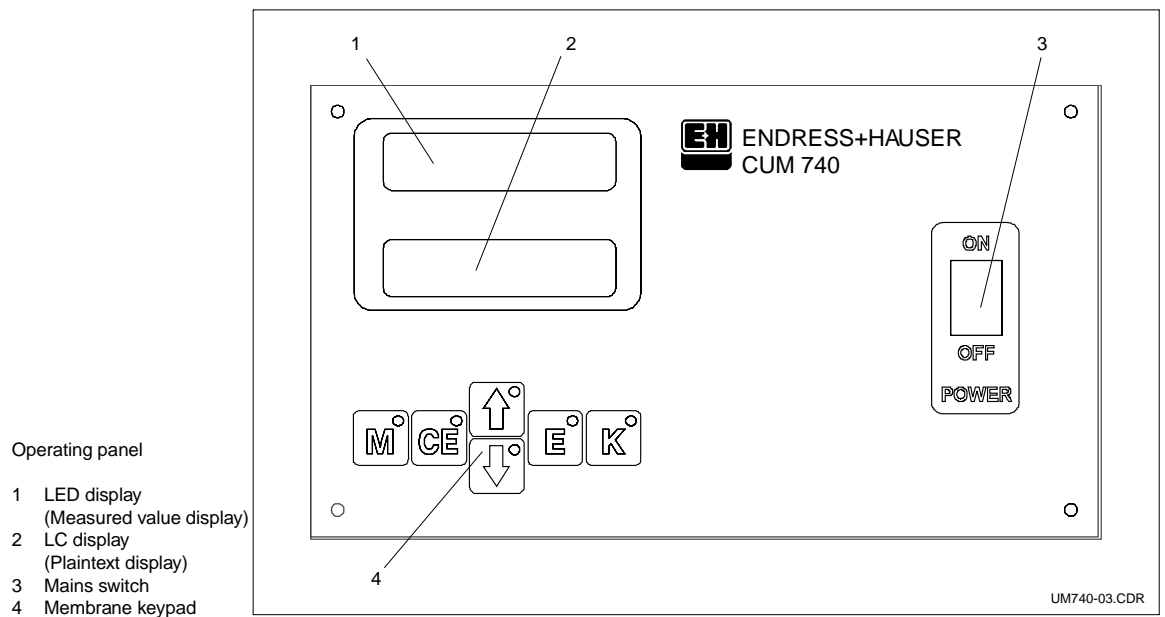

Functions

The 16-bit processor offers the following possibilities for signal evaluation:

- Measured value detection, display and evaluation
- Menu control with alpha-numeric LC display
- Measuring system monitoring incl. sensor
- User parameter storage and management

All instrument control functions are arranged in a logical menu structure.

Operating panel	Function
MEASUREMENT	Detection, evaluation and display of sensor signal, analogue current and sensor frequency
PARAMETER ENTRY	Measuring range selection, limit setting, measured value damping setting, cleaning interval setting
CALIBRATION	Sensors calibrated using stored calibration curves or using application-specific customer standards
ASSIGN	Calibration value assignment to appropriate sensor signals
FREQUENCY	Retrieval and option for manually editing measuring frequencies determined during calibration
CONFIGURATION	Sensor type selection, measuring unit selection, calibration factor setting, analogue output configuration, alarm relay configuration
LANGUAGE	User interface in your own language
ERROR DISPLAY	Error message display

Dimensions

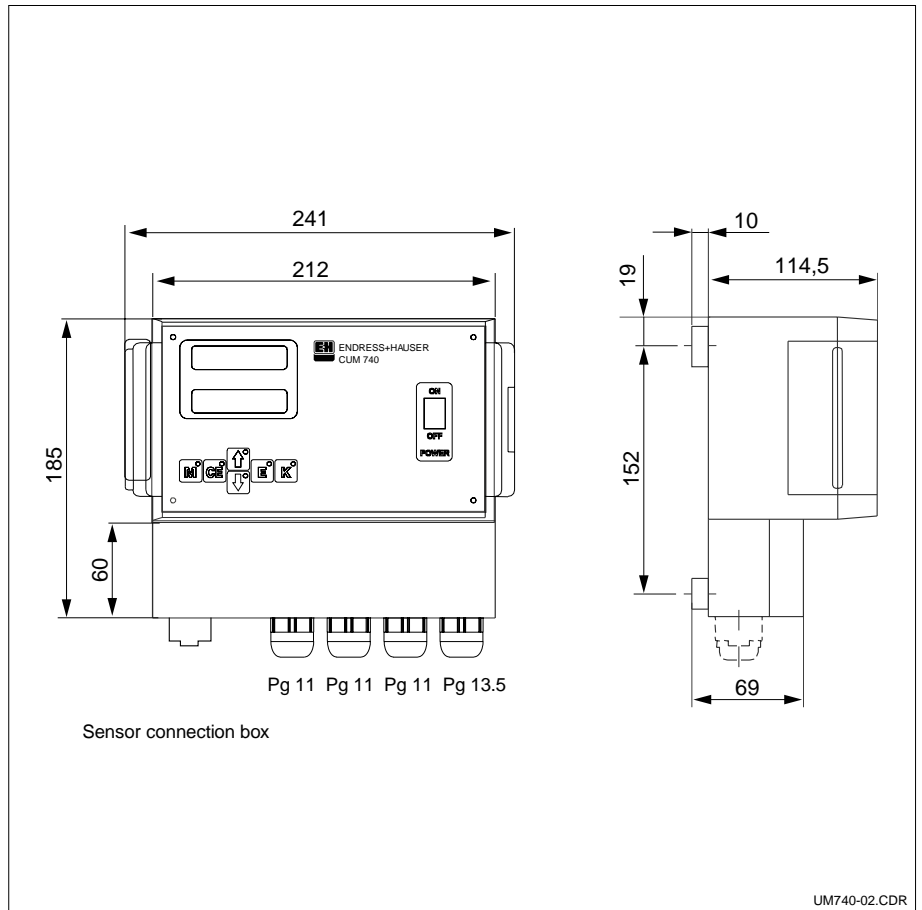

Installation

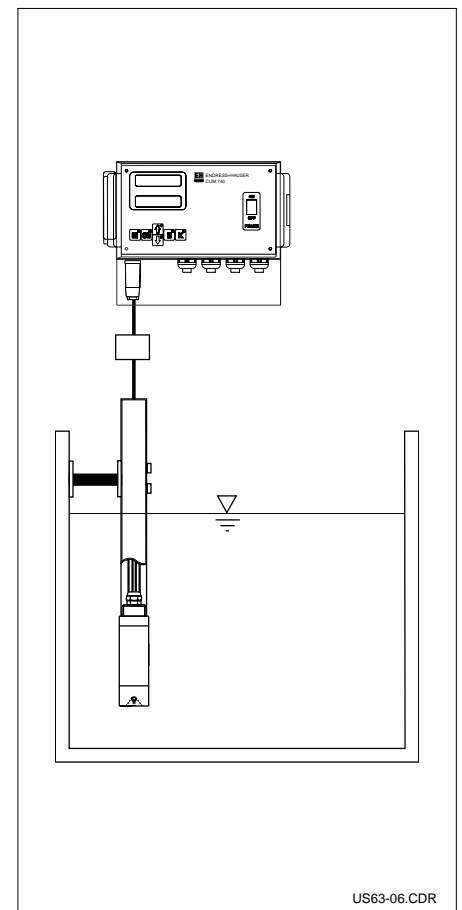
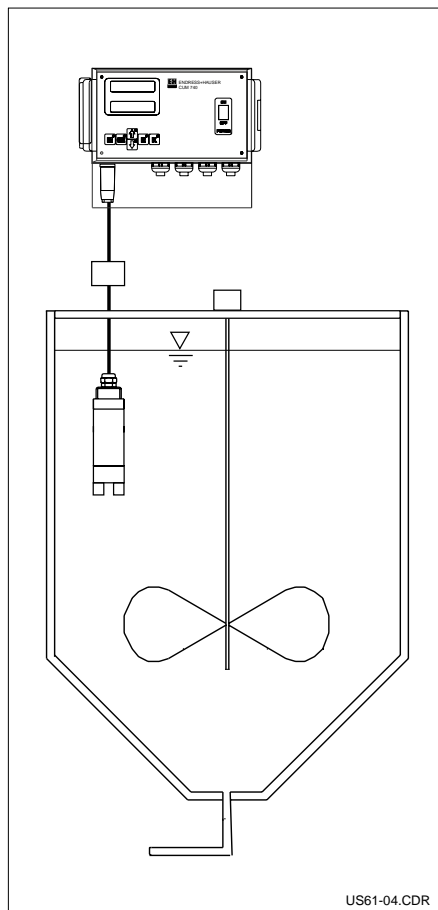

Installation

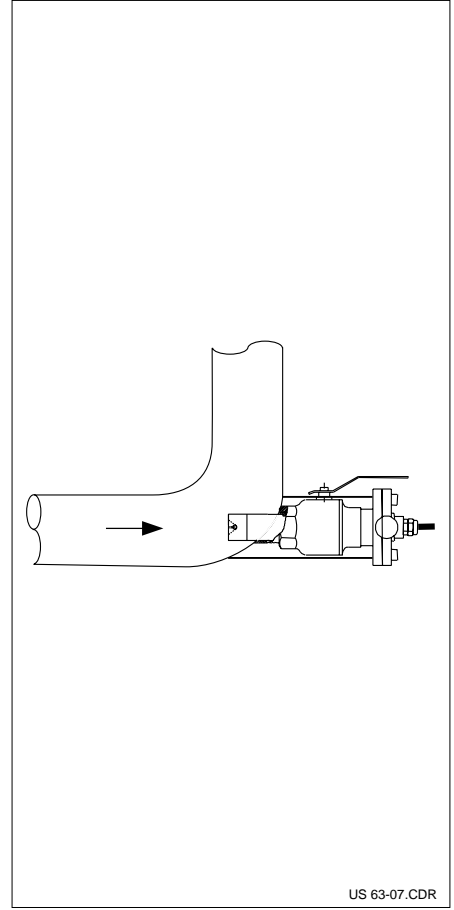
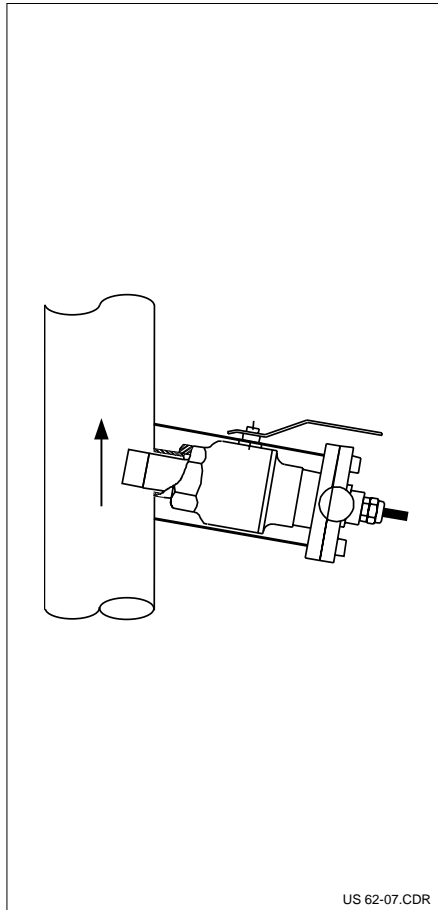

Installation examples

left:
Pipe mounting
with CUS 62

right:
Pipe mounting
with CUS 63

US 62-07.CDR

US 63-07.CDR

Accessories

- ❑ Weather protection cover for wall mounting
Order no.: 50061258

- ❑ Upright post for weather protection cover
Order no.: 50064291

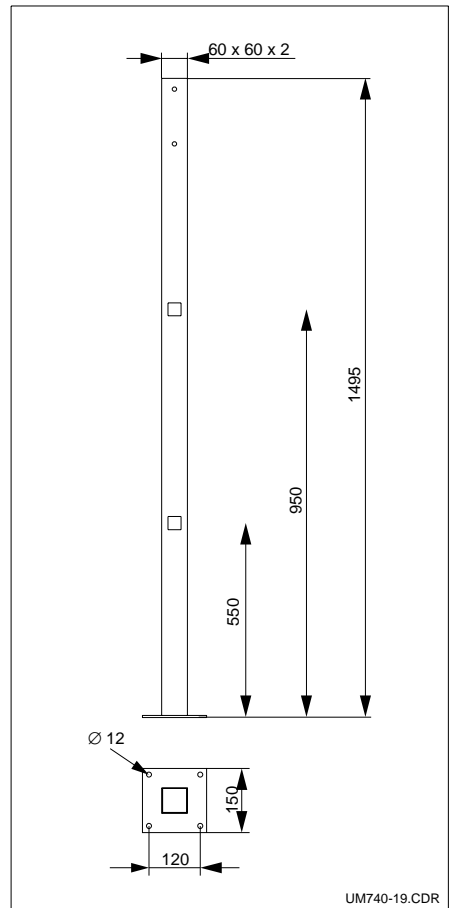
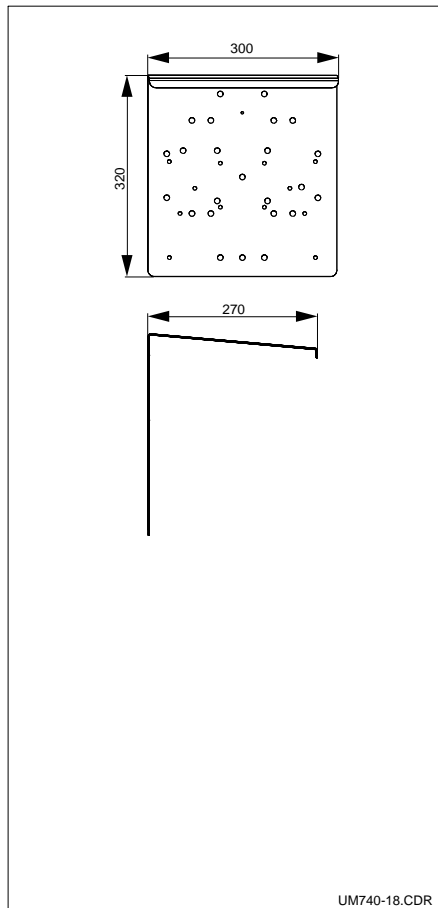

Accessories

left:
Weather protection
cover

right:
Upright post
for weather protection
cover

UM740-18.CDR

UM740-19.CDR

Technical data

General data	Manufacturer	Endress+Hauser
	Instrument designation	Transmitter CUM 740 for turbidity and solids content
Mechanical data	Dimensions (l x w x d)	185 x 241 x 114.5 mm
	Weight	1.6 kg
	Display	LED display (12mm) for displaying measured values, 2-line LC display (5mm) for set-up
Materials	Housing	Polycarbonate
	Sight glass	Plexiglas®
Input	Parameters	Turbidity and solids content measurement
	Measuring principle	Four-beam pulsed light method
	Measuring light	Infrared light
	Wavelength	880nm (absorption maximum)
	Measuring range	Dependent on connected sensor
	Accuracy	≤ 1% from measuring range end value
	Reproducibility	0.5%
Output	Signal output	0/4 ... 20mA
	Number of signal outputs	max. 2
	Load	max. 500Ω
	Switching outputs	1 relay contact for sensor cleaning, 1 relay contact for Hold function, 1 relay contact for error messages, 2 limit contact freely configurable
	Switching power	3A at 115V/230VAC, 1A at 24VAC/VDC
	Interfaces	RS 232, port for bus extension
Electrical connection	Power supply	230/115VAC, 50/60Hz +6 ... -10%, 24VAC/VDC
	Power consumption	max. 15VA
Ambient conditions	Ambient temperature	-20 ... +60°C
	Ingress protection	IP 65
Supplementary documentation	Technical Information CUS 61 /CUS 61 H	Order No.: 51504289
	Technical Information CUS 62	Order No.: 51504291
	Technical Information CUS 63 /CUS 63 H	Order No.: 51504293
	Technical Information CUS 64	Order No.: 51504295

Subject to modifications.

Product structure

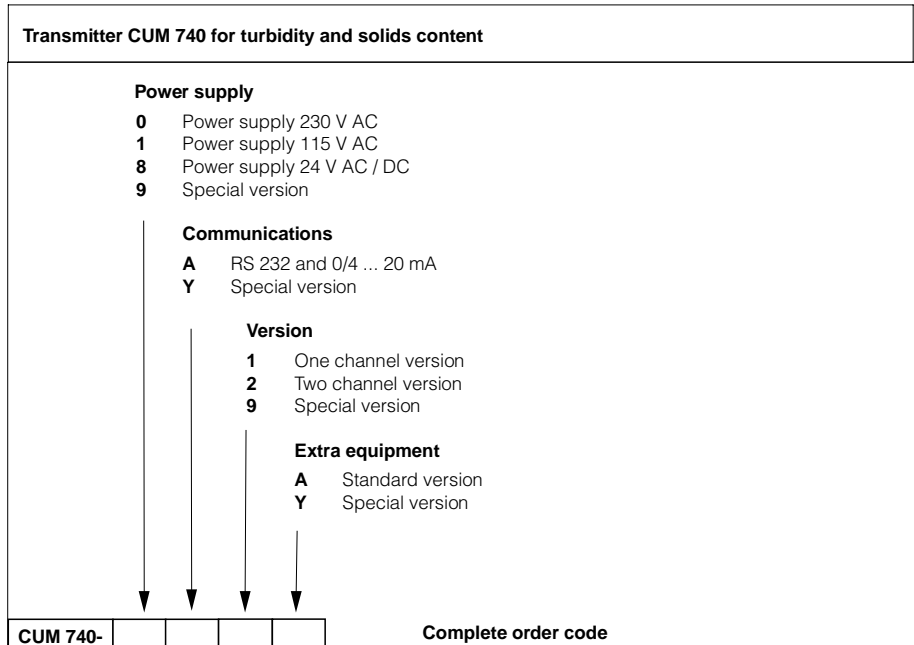

Endress+Hauser
GmbH+Co.
Instruments International
P.O. Box 2222
D-79574 Weil am Rhein
Germany

Tel. (0 76 21) 9 75-02
Fax (0 76 21) 9 75-345
<http://www.endress.com>
info@ii.endress.com

Endress+Hauser
The Power of Know How

